

Computer Networks and QoS

- QoS
- ATM
- QoS implementations
- Integrated Services
- Differentiated Services

Quality of Service (QoS)

- The data transfer requirements are defined with different QoS parameters
 - + e.g., delay, jitter, error rate, capacity
- The customer negotiates the QoS parameters with the service provider before the use of service
- The highest protocol level is used in negotiations
- Parameters are transformed and distributed to the lower levels

QoS Parameters

- Bandwidth
- Delay
- Jitter
- Error rate
- Best effort / guaranteed

ATM

- Can be used both voice, data, and multimedia transfer
- ATM uses 53 byte cells
- The switching of cells is fast (ASIC circuits)
- Optical fiber: 155 Mbps, 622 Mbps, 2.5 Gbps
- Twisted pair: 25 Mbps
- QoS parameters have to be agreed before hand

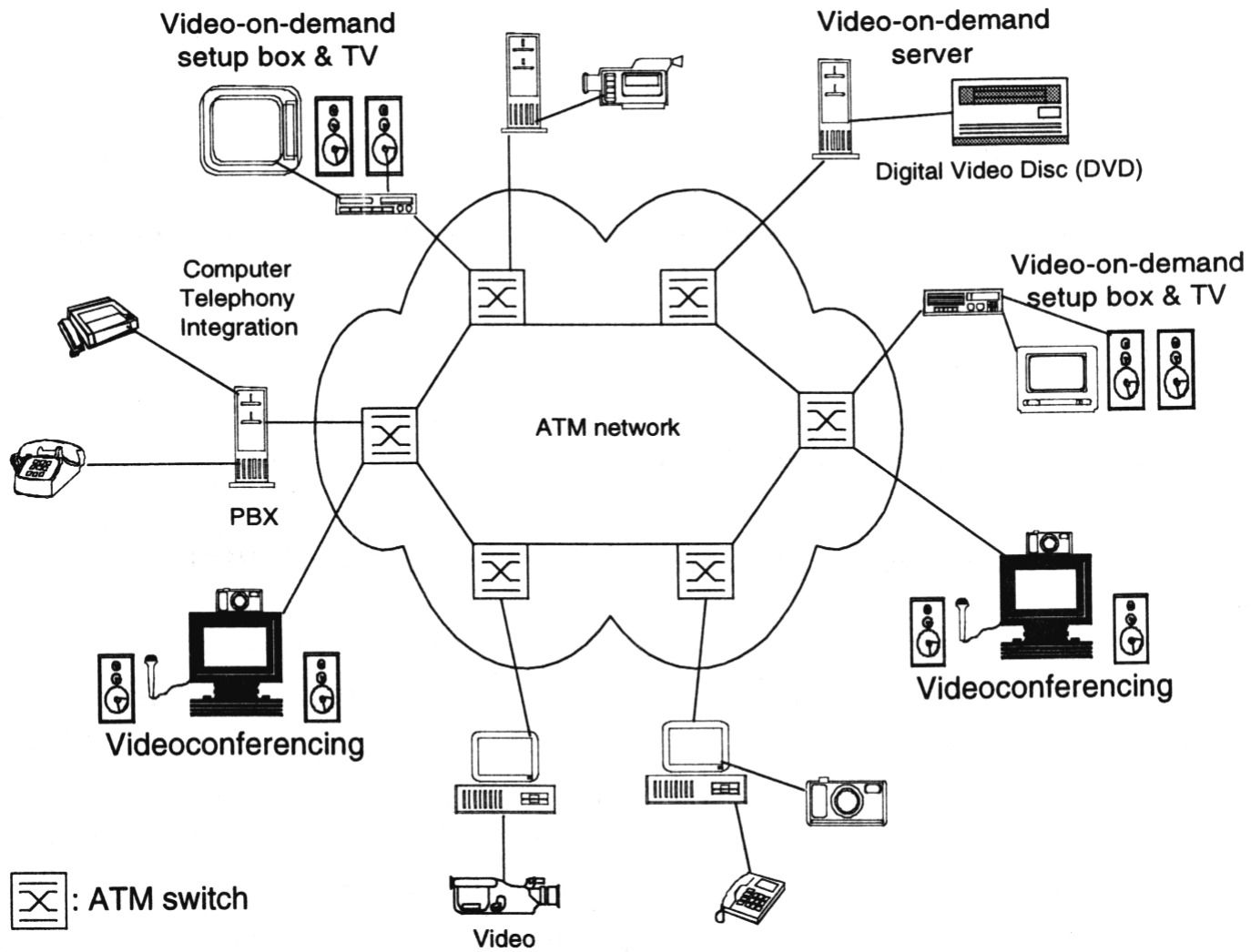

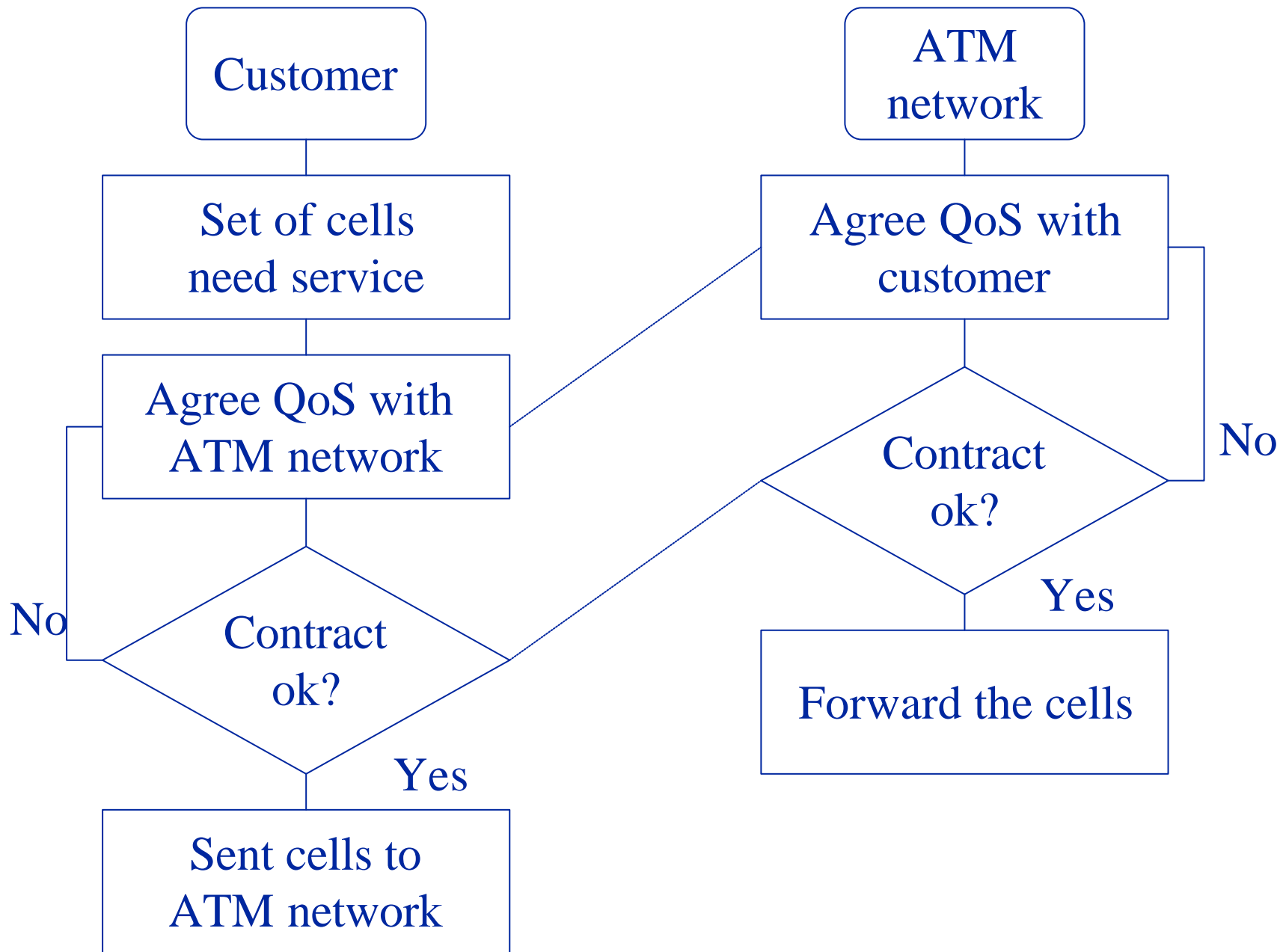

Cell Switching

- ATM network builds connections, which go through the ATM switches
 - + Virtual Circuit Connection (VCC)
- Two ATM switches have a Virtual Connection (VC)
- Connections can be either permanent (PVC) or switched (SVC)

Cell Switching (cont.)

- Several connections can share a path
 - + Virtual Path (VP)
- Virtual paths have a identification pair
 - + VP Identifier / VC Identifier (VPI/VCI)

ATM Switch

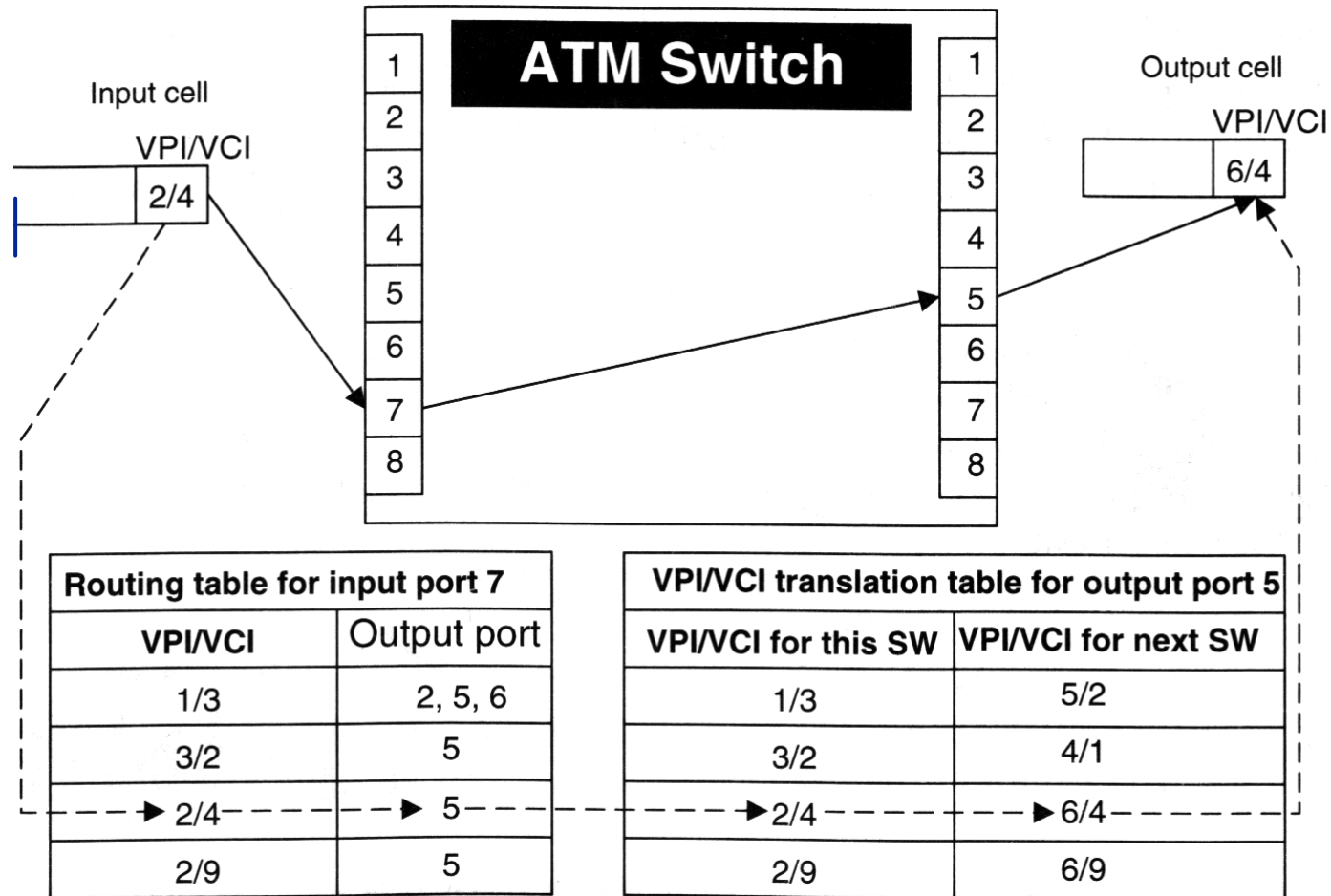

Signaling

- Connection setup requires signaling
- First the QoS requirements are checked and then the success of connection
- Private network:
 - + User Network Interface (UNI)
 - + Private-Network Node Interface (P-NNI)

Adaptation Layers

- AAL1: audio and video
- AAL2: variable bit rate
- AAL3: connection data
- AAL4: connectionless data
- AAL5: LAN emulation

ATM Adaptation Layers

	AAL1	AAL2	AAL3	AAL4	AAL5
Timing	Isochronous		Bursty		Both
Data Rate	Constant	Variable			Both
Connection	Connection-oriented			Connectionless	Both
Applications	Voice & circuit emulation	Compressed video and audio	Data	Data	All

QoS Implementations

- The task of the router is to forward the incoming packets to correct output port
 - + the responsible unit is scheduler
 - + scheduler can be implemented as software or hardware
 - + individual packets have to wait their turn in buffer
- Also in ATM switch scheduler controls individual cells

Router Operation

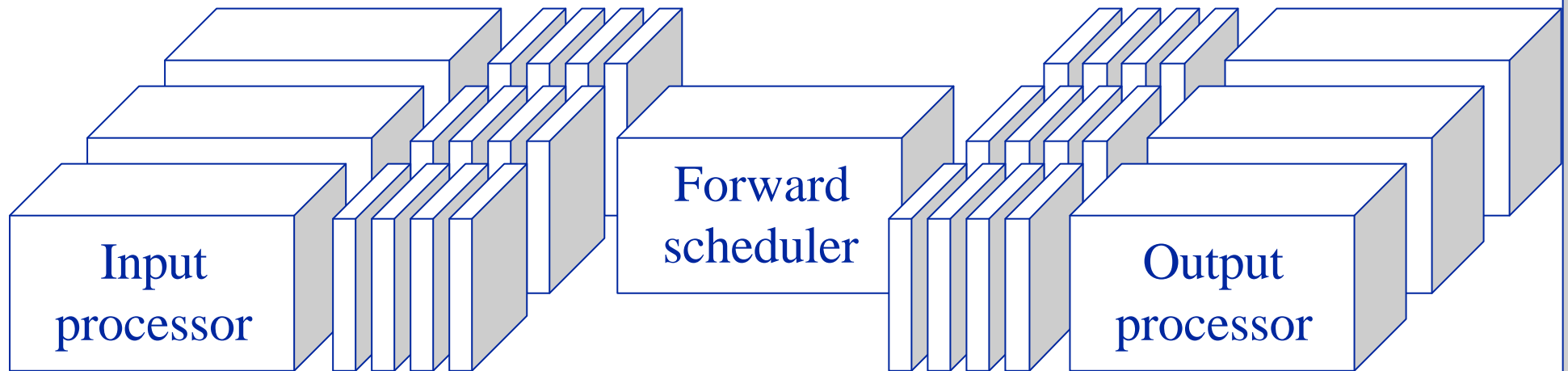

Queuing

- If the queue is full, the packet has to be discarded
 - + Buffers should not get full
- Most simple queue is so called FIFO queue
 - + the first arrived packet is forwarded to right output queue (first-in-first-out)

FIFO Queue

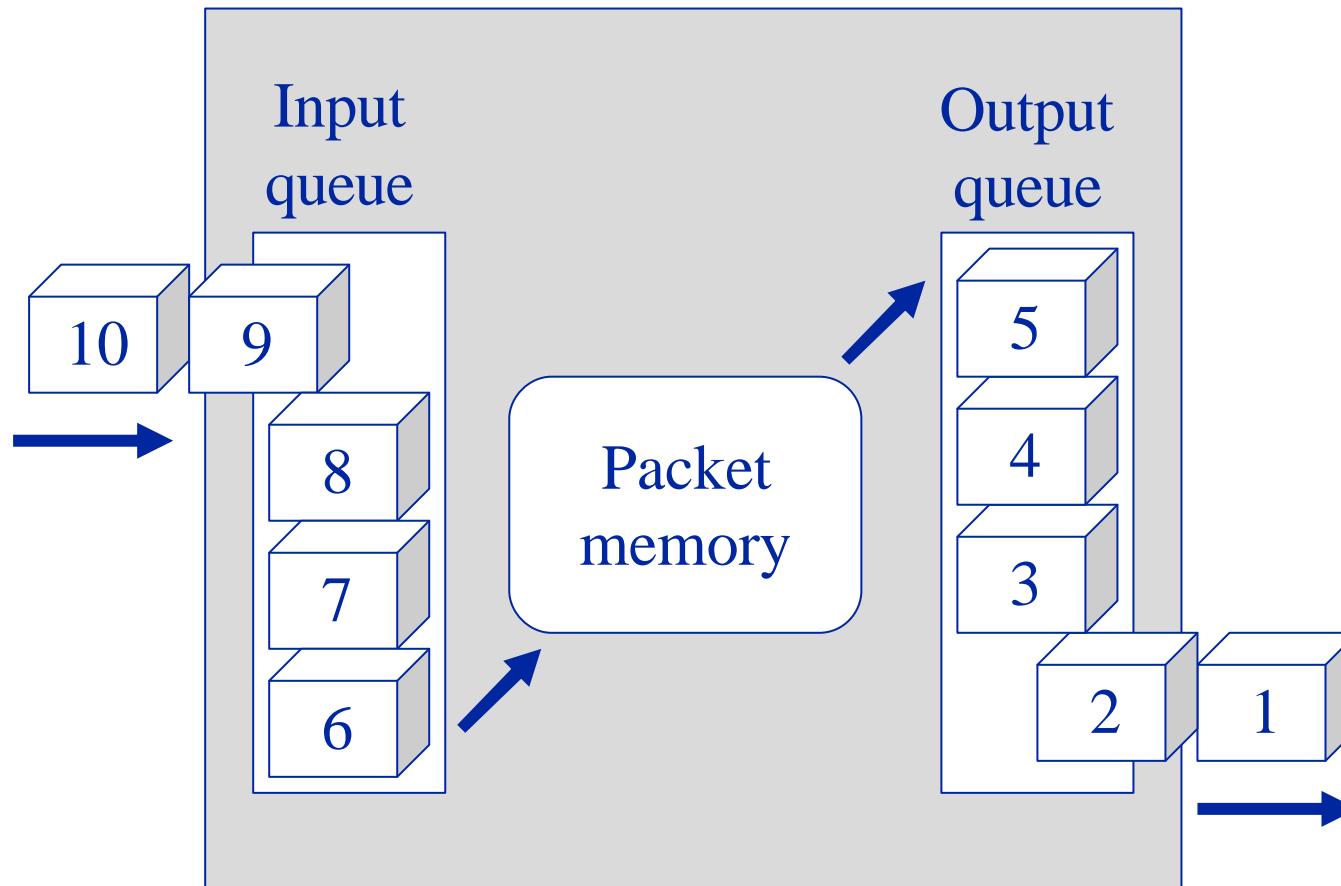

Pros and Cons

- FIFO queue filters well bursts, when the load level is low
- When the load is high, FIFO causes delay for all packets
 - + high priority traffic suffers
 - + if queue gets full, all further incoming packets are discarded

Priorities

- The simple solution is to prioritize the traffic
 - + e.g., real-time traffic has higher priority
- Packet classification causes extra work load

Priority Queue

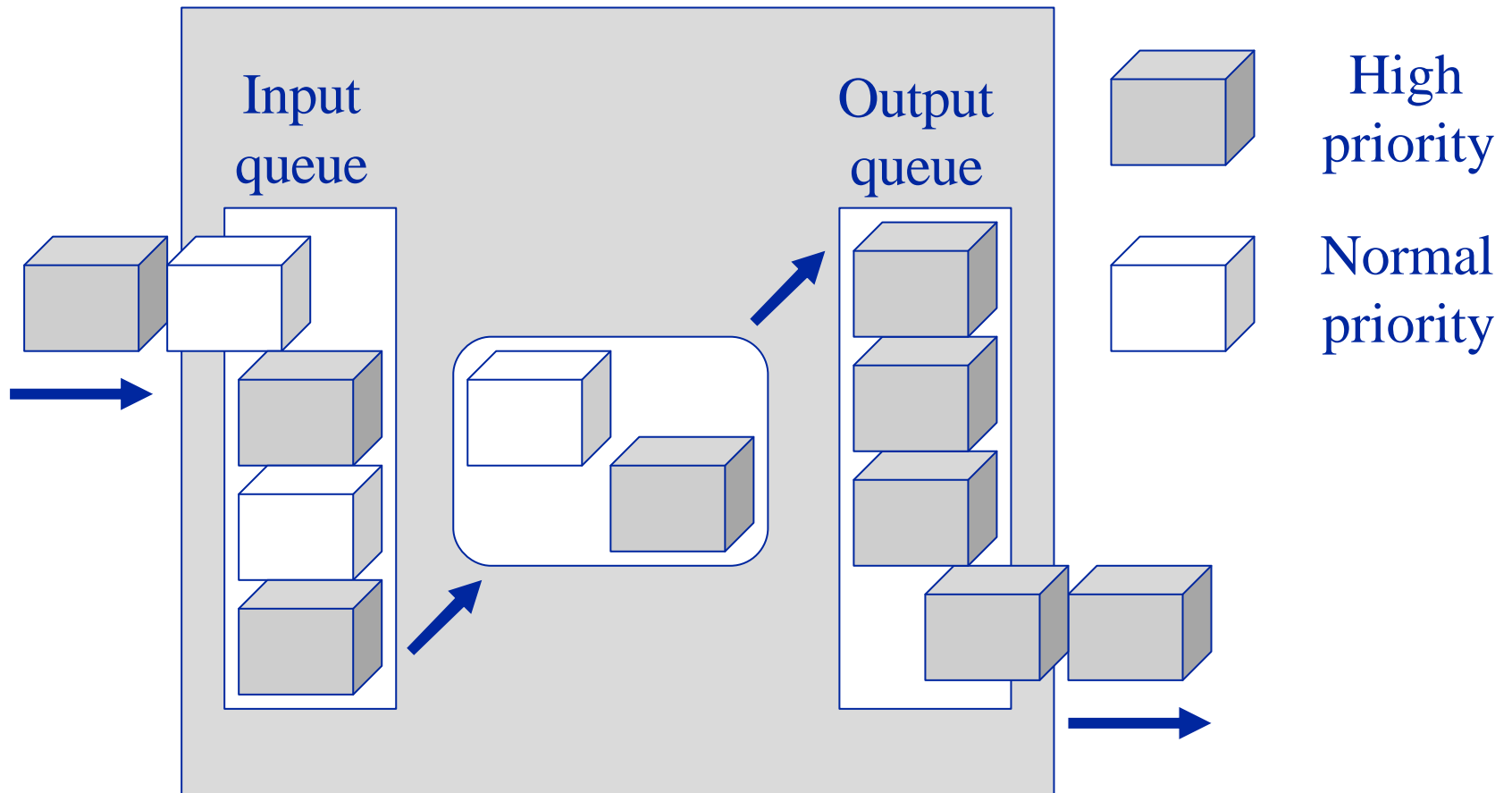

Pros and Cons

- Scheduler implementation is simple
- Classification is difficult
- High priority traffic can block the router
 - + low priority traffic stalls

Service Classes

- Different services can have their own output queues
 - + high priority traffic does not stall low priority traffic
- Several output queues are required

Class Based Queue

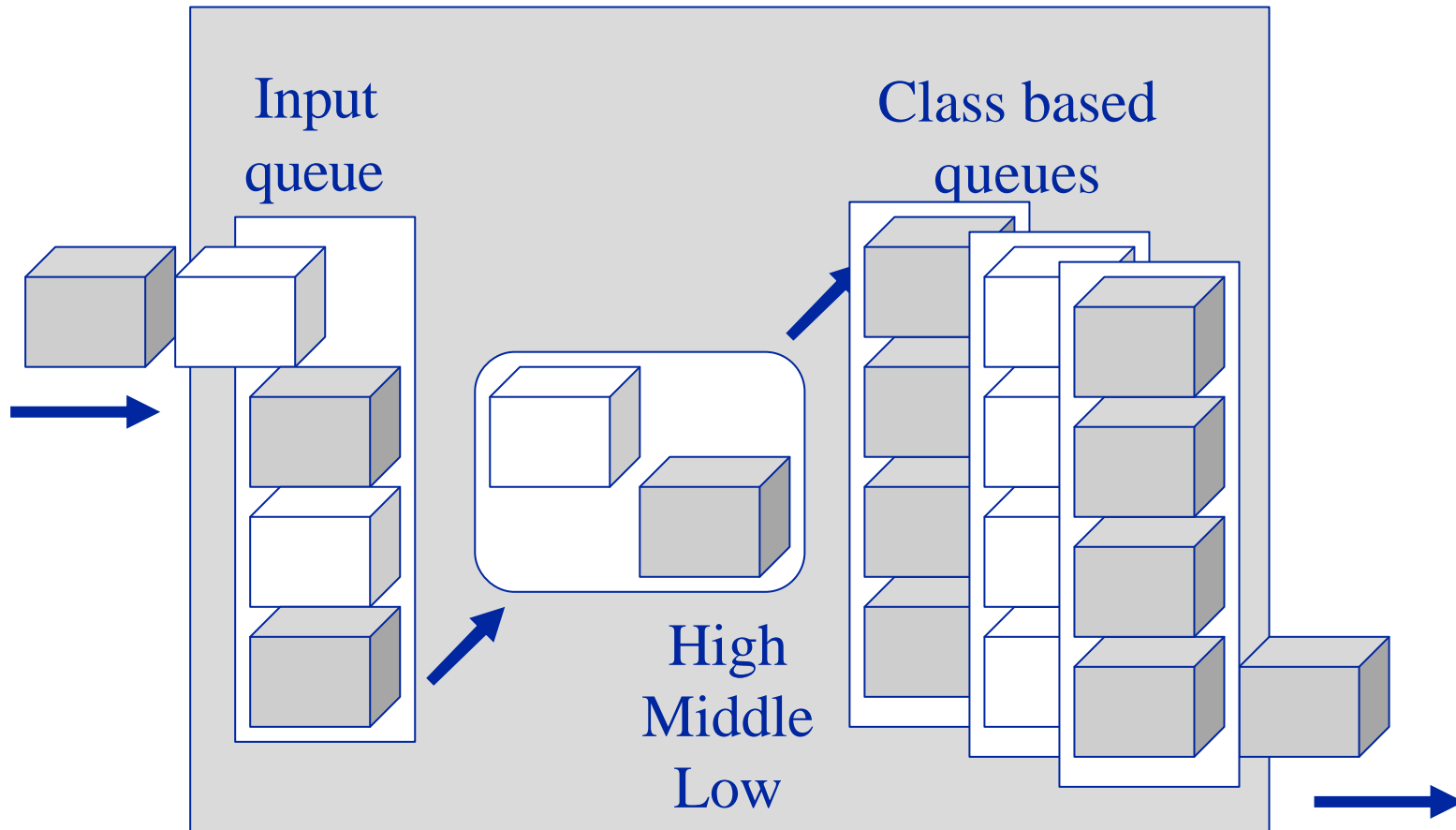

Pros and Cons

- Simple way to classify traffic
- Does not scale well
 - + scheduling is complicated
 - + queue control slows down the fast traffic

Weighted Queues

- Weighted Fair Queuing (WFQ)
- Capacity is divided according to the amount of traffic
 - + low capacity traffic gets the higher priority
 - + high capacity traffic shares the rest of resources
- Traffic can be divided into flows
 - + Each flow is assigned into a buffer according to the amount of traffic

Weighted Fair Queuing

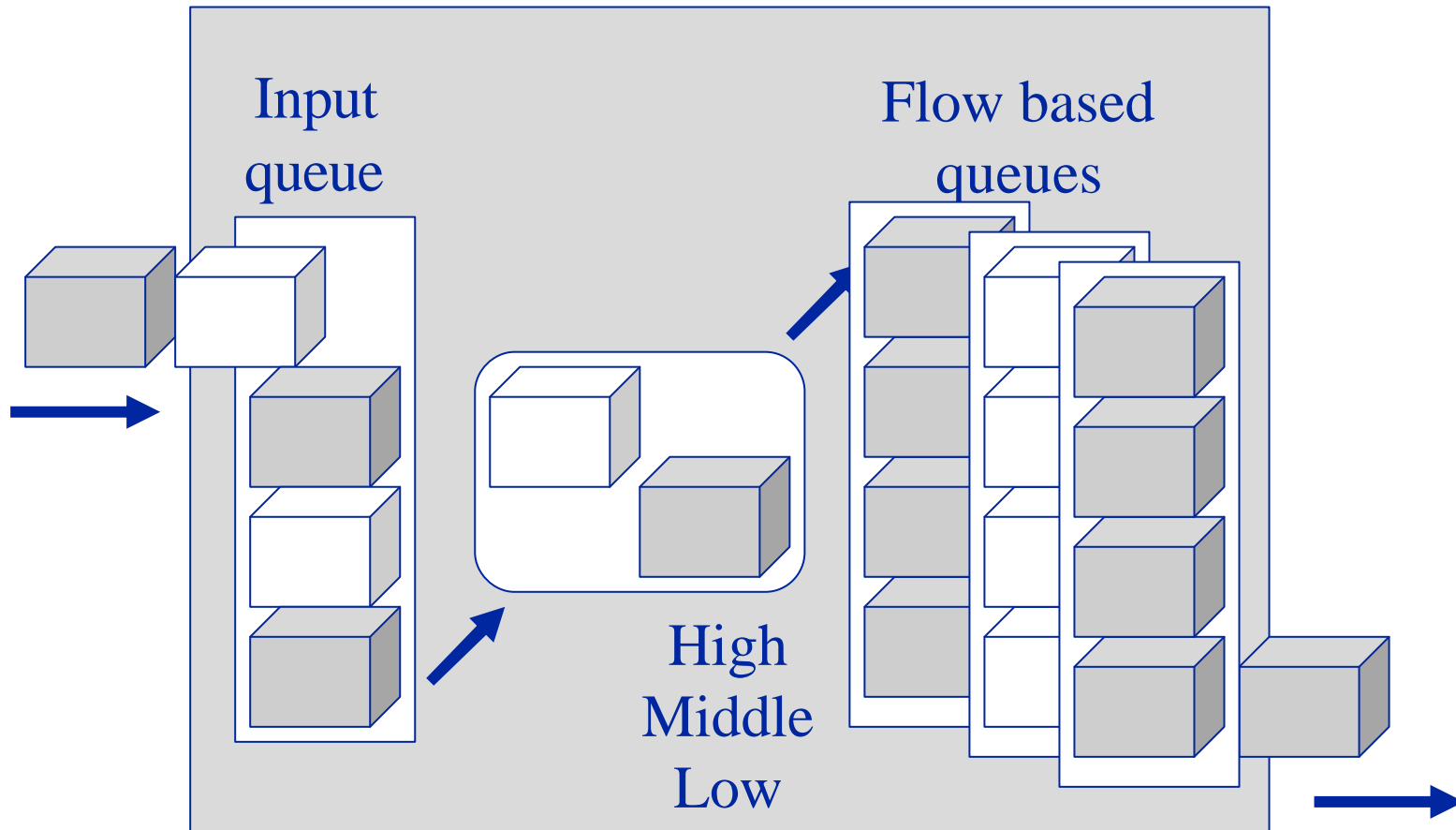

Pros and Cons

- **Fairness**

- + one flow does not block all other traffic

- **Scalability**

- + computation creates extra load

- **Classification**

- + how different flows are assigned to groups

Traffic Shaping

- Individual traffic flows are shaped more suitable
 - + packet put to wait in queues
 - + packets are discarded
- It is also possible to shape incoming traffic
 - + Not necessarily a competing method, but rather supporting with queuing

Burst Filtering

- Most simple method to shape traffic is to filter bursts
- So called leaky bucket algorithm can be used
 - + too large traffic bursts are filtered
 - + if necessary, packets are discarded
- Was used originally in ATM networks

Leaky Bucket

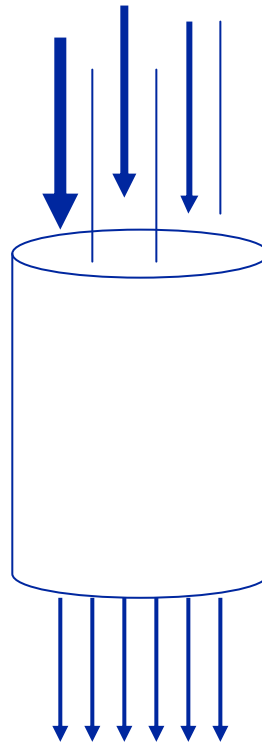

Token Bucket

- A token is required to sent a packet
 - + a bucket is used, which can hold B tokens
 - + R tokens enter the bucket per second
- Tokens are saved in bucket if they are not used
 - + bursts are allowed to certain limit

Token Bucket

R tokens
per second

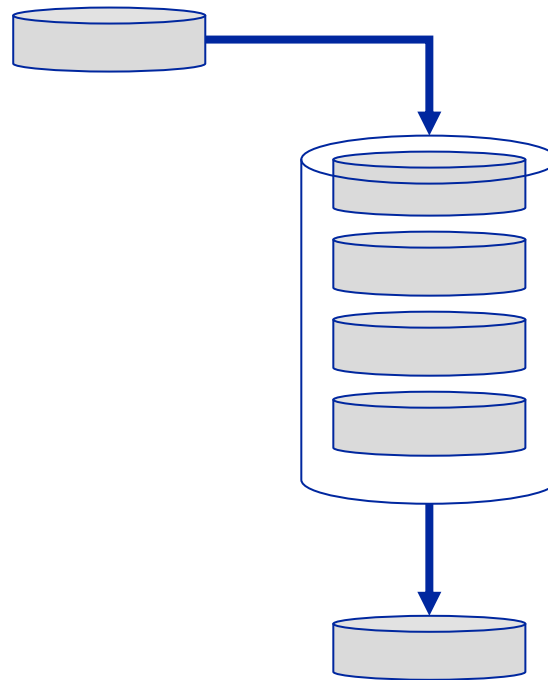

B tokens

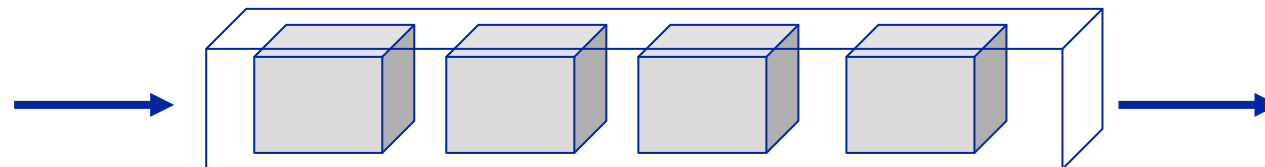

Random Early Detection (RED)

- The objective is to prevent TCP/IP traffic from stalling
 - + the packets are discarded with larger likelihood, when the amount of traffic grows
- Suits well with TCP protocol
 - + individual TCP protocols drop speed, when packets are lost
 - + the effect doesn't happen at the same time

RED

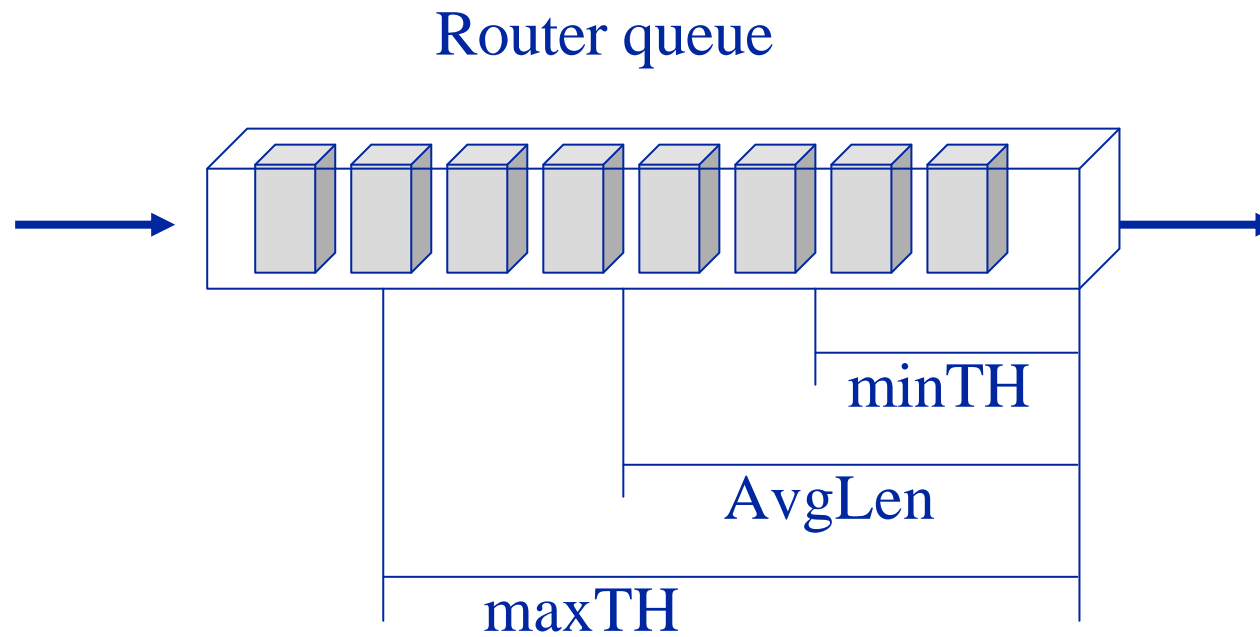

Conclusion

- Routers (and switches) have big influence on the QoS properties of the network
- This can be utilized in the implementation
 - + different queues
- Individual traffic flows can be shaped
 - + leaky bucket, token bucket, RED

Integrated Services

- Integrated Service Architecture work was started 1994
- Designed to provide a set of extensions to the best-effort traffic model of Internet
- Basic underlying Internet architecture should not be modified
- Similar to the ATM model of QoS

Objectives

- Define the services to be provided
- Define the interfaces for
 - + Application service
 - + Router scheduling
 - + Link-layer
- Define router validation requirements

Implementation

- Real-time applications require resource reservation
- Reservation requires admission control
- Five key components
 - + QoS requirements
 - + resource-sharing requirements
 - + allowance for packet dropping
 - + provision for usage feedback
 - + resource reservation protocol (RSVP)

QoS Requirements

- Focus on real-time QoS classes
- Latency and jitter are most important issues
- Two QoS-classes
 - + Controlled load service
 - + Guaranteed QoS Service Class

Controlled Load Service

- Approximates traditional best-effort services in unloaded condition
 - + Better than best-effort
- Uses token bucket filter
- Each node handling the controlled load service request ensures that sufficient resources are available

Guaranteed QoS Service Class

- Bandwidth and delay guarantee
- Also uses the token bucket filter
- Measures end-to-end QoS
- Calculates end-to-end and hop-by-hop error terms
 - + Cumulative delay (measured in bytes)
 - + Delay caused by a node (measured in microseconds)

Reference model

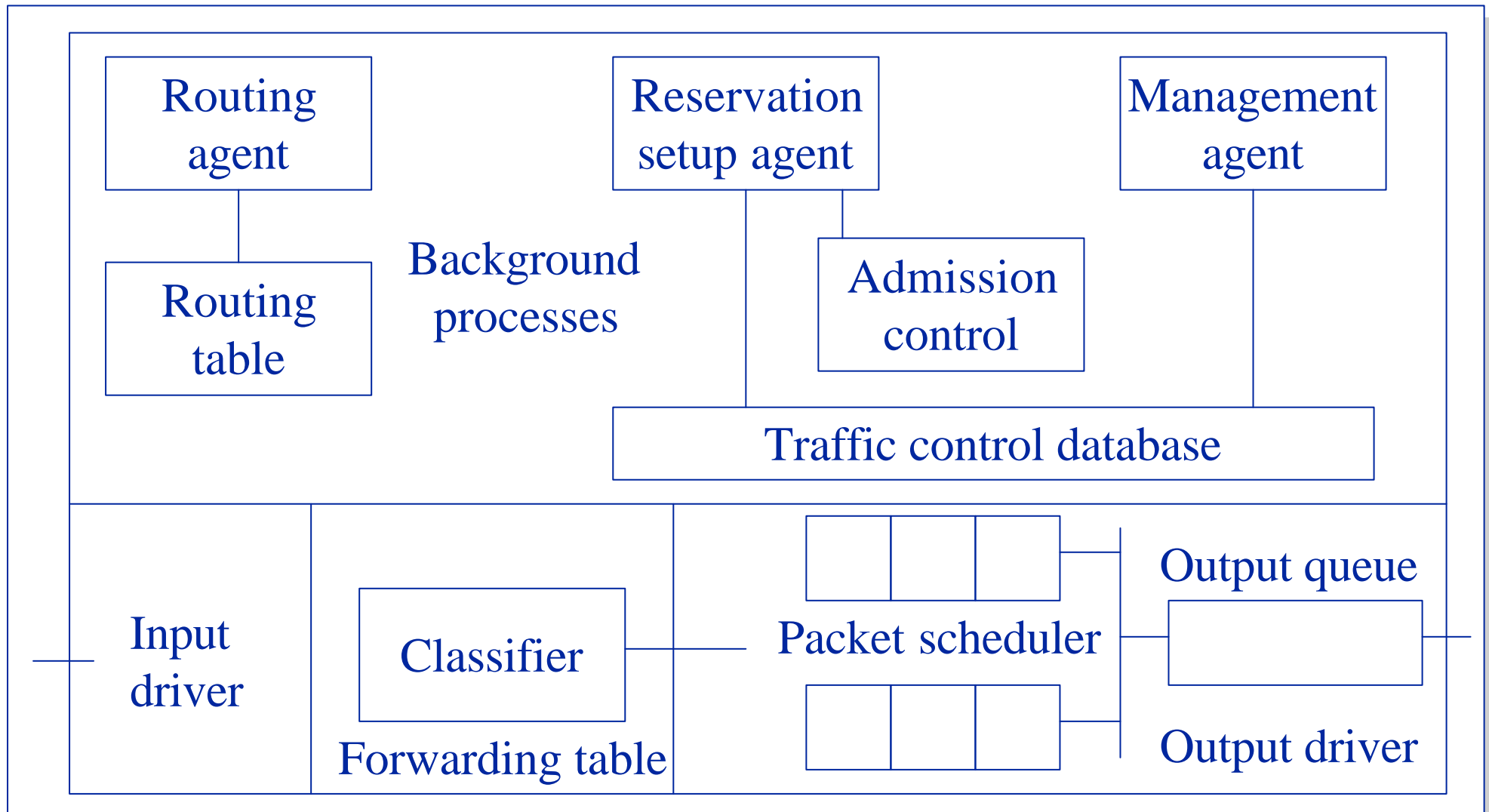

Resource Sharing Requirements

- Allocation for network resources is accomplished on a flow-by-flow basis
 - + Different network protocols (e.g., IP, IPX, SNA)
 - + Different services within the same protocol suite (e.g., Telnet, FTP, SMTP)
- Different traffic flows should not unfairly utilize more than their fair share of network resources

Allowance for Packet Dropping

- Traffic control is provided by dropping packets
- Packets may be preemptable or subject to drop
- Similar to Random Early Detection (RED)

Conclusions

- Scalability is a big issue
 - + What is ISP-router has 10 000 flows?
- Lacks security
 - + Service attacks
- Special Link-Layer
 - + ATM virtual circuit

Differentiated Services Objectives

- **Solution has to scale**
 - + individual micro-flows are aggregated into a single larger aggregate flow
 - + the aggregate flow receives special treatment
- **Applicable to all applications**
 - + no special control protocol (i.e., RSVP)
- **Gigabitrate operation**
 - + no new application programming interfaces
 - + 2.4 and 10 Gbps line rates are coming
- **ISPs want to offer portfolio of service**
 - + versioning
 - + QoS classes

Service Classes

- Individual microflows are classified at the edge of the network
- Several unique service classes
 - + E.g., Gold, Silver, Bronze
- Per-class service is applied in the middle of network
- Classification is based on one or more fields in the packets

Components

- **DS-Field:** denotes the service the packet should receive
 - + IPv4: Type-of-service
 - + IPv6: Traffic class
- **Per-hop behavior (PHB):** defines the service the packet receives at each hop
- **Behavior aggregate (BA):** group of similar packets

Components (cont.)

- **Boundary router: positioned at the edge of the DiffServ-capable network**
 - + Packet classification
 - + Metering
 - + Marking
 - + Traffic conditioning
- **Interior router: core switches or routers that provide PHB**

Reference Model

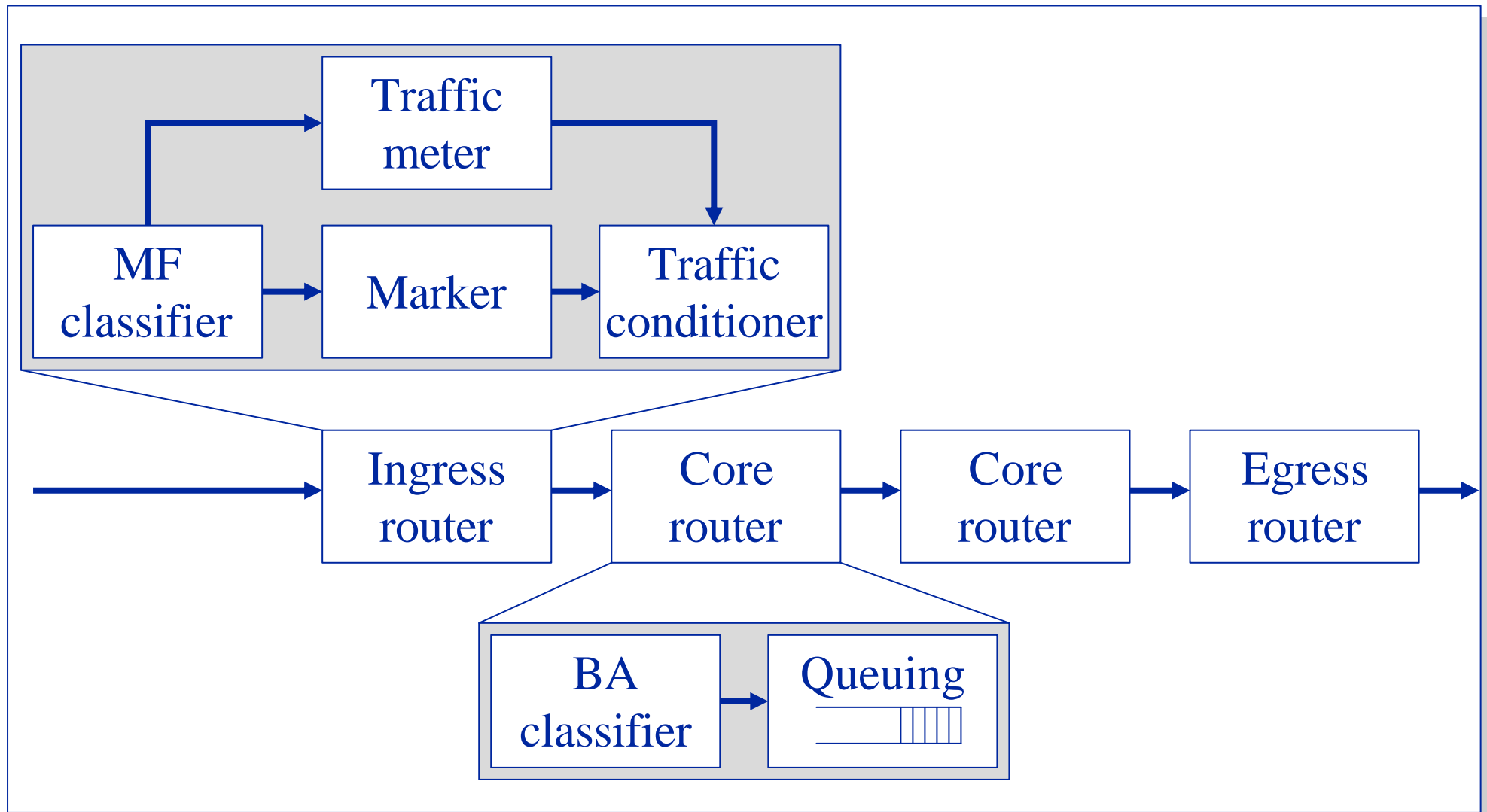

Per-hop Behavior

- IETF DiffServ Working Group has defined two PHBs:
 - + Expedited forwarding (EF)
 - + Assured forwarding (AF)

Expedited Forwarding (EF)

- Supports low loss, low delay, and low jitter connections
- Point-to-point virtual leased line
- Peak bandwidth
- Packets must spend minimum time in router queues
- Traffic is conditioned to the peak rate

Assured Forwarding (AF)

- Four relative classes of service
 - + just distinct classes
- Each service class has three levels of drop precedence
 - + high precedence packets are dropped before low precedence packets
- In total, twelve combinations

Open Questions

- How network policies are managed?
 - + Manual configuration
 - + Simple Network Management Protocol (SNMP)
 - + Lightweight Directory Access Protocol (LDAP)
 - + Common Open Policy Server (COPS)
- How to extend across ISP boundaries?
 - + Bilateral agreements
 - + Bandwidth brokers