

# Access Networks

- Introduction
- Cable television
- Digital subscriber lines
- UMTS
- Digital television
- Conclusions

# Introduction

- Wideband networks do not reach homes
- Fiber is too expensive to be installed everywhere
- Current networks have to be made wider
  - + cable, ADSL, digital TV, electric network
- Mobile users need a wireless network
  - + UMTS
- In addition, the home networks have to be renewed
  - + wireless local area networks (WLAN), Firewire

# Cable television

- Community Antenna Television (CATV)
- In Finland, about 900 000 households are connected to cable TV system
- Several operators (e.g., local telephone operators)

# Architecture

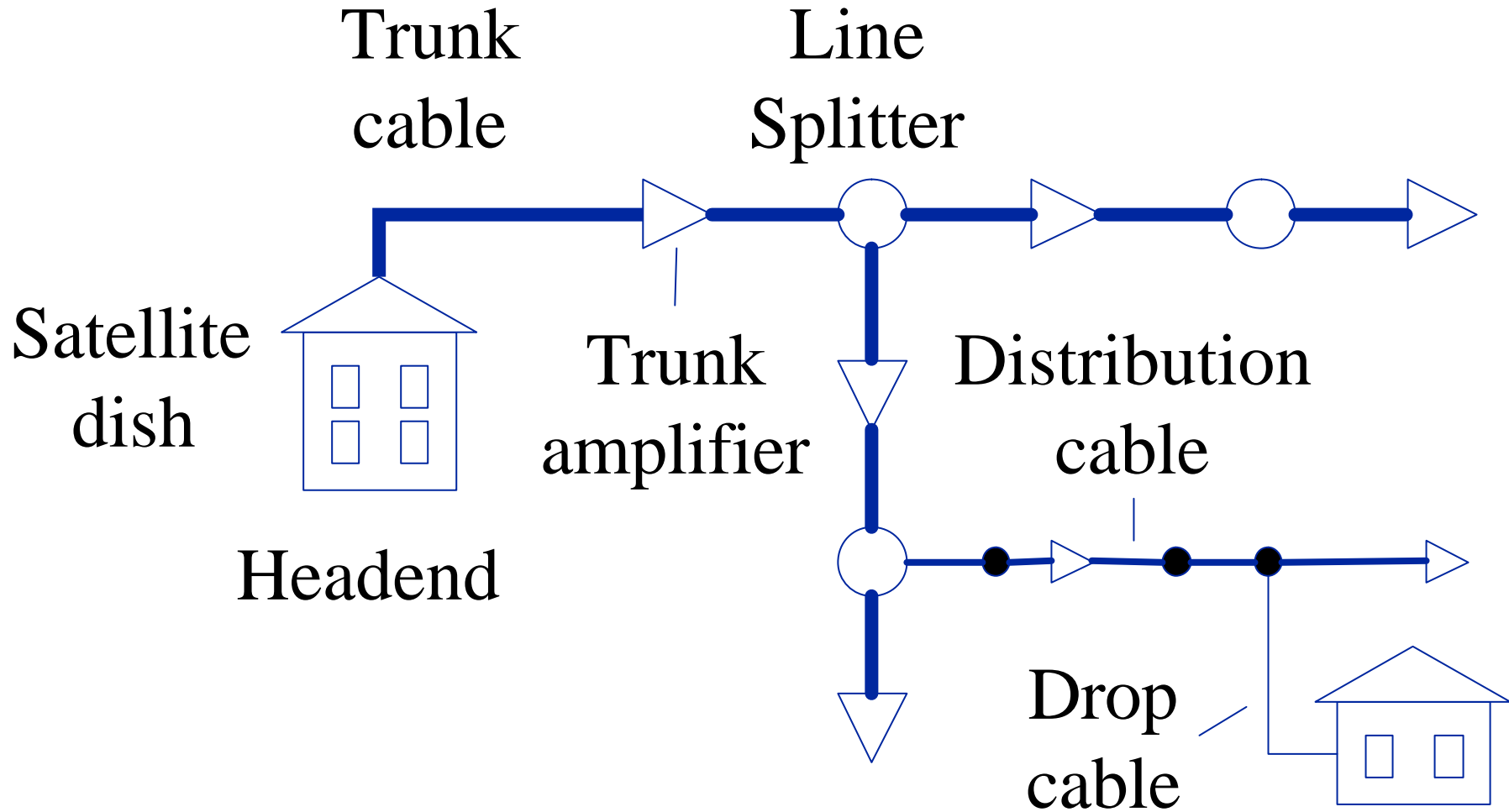

# Home cable modem interface

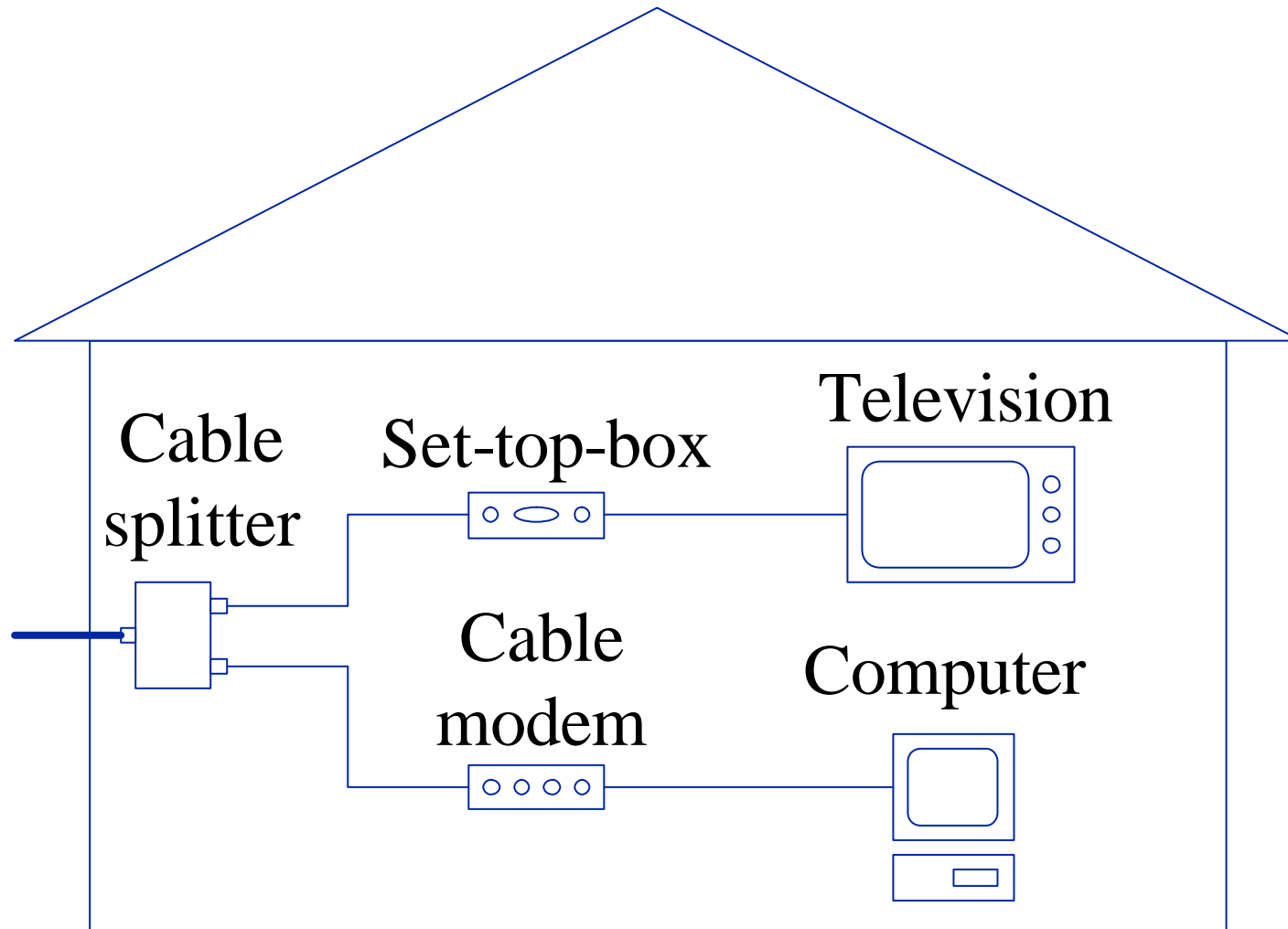

# Hybrid network

- Originally fully coaxial cable
- Since 80s also optical fiber
- Hybrid Fiber Coax (HFC)
- NTSC signal requires about 4.3 MHz
- To prevent overhearing 6 MHz per channel used
- Depending on the quality of the network different systems can be implemented

# Different systems

<b>Size</b>	<b>Band</b>	<b>Frequencies</b>	<b>Channels</b>
Small	170 MHz	50 – 220 MHz	12 – 22
	220 MHz	50 – 270 MHz	30
Middle	280 MHz	50 – 330 MHz	40
	350 MHz	50 – 400 MHz	52 / 104
Large	400 MHz	50 – 450 MHz	60 / 120
	500 MHz	50 – 550 MHz	80
	700 MHz	50 – 750 MHz	110
	950 MHz	50 – 1000 MHz	150

# Data service

- Cable network is originally unidirectional
- Data services requires bi-directional connection
- Amplifiers have to also bi-directional
- Optical fiber should come closer to consumer
- Fiber to the Home (FTTH)
- Fiber to the Neighborhood (FTTN)
  - + Fiber to the Curb (FTTC)
  - + Fiber to the Basement (FTTB)

# New services

- A cable modem is required for bi-directional data services
- In addition cable network should be updated
  - + amplifiers bi-directional
  - + modem banks installed
- Allows the use of Internet, video-on-demand, etc.

# Cable modems

- Most of the cable modems support bi-directional communication
  - + different speed downlink and uplink
- Some modems can be used also for telephony
- Some modems use telephone line for uplink
  - + cable network can remain unidirectional

# Standards

- Compatibility between different manufacturers can be quarantined with standards
- Two standards in use:
  - + DVB (Europe)
  - + DOCSIS (USA); also EuroDOCSIS version
- Final decision about the standard in Finland has not yet been made

# HTV cable modem service

- Welho 525:
  - + Subscription 30 €
  - + Monthly fee 25 €/month
  - + Cable modem rent 6 €/month
  - + Together 31 €/month

# Digital subscriber lines

- Digital subscriber lines use existing telephone twisted pairs
- Modems are based on efficient signal processing
- Digital subscriber lines bring wideband connections to homes
- The technology can also be used in small offices / home offices (SOHO)

# Home ADSL connection

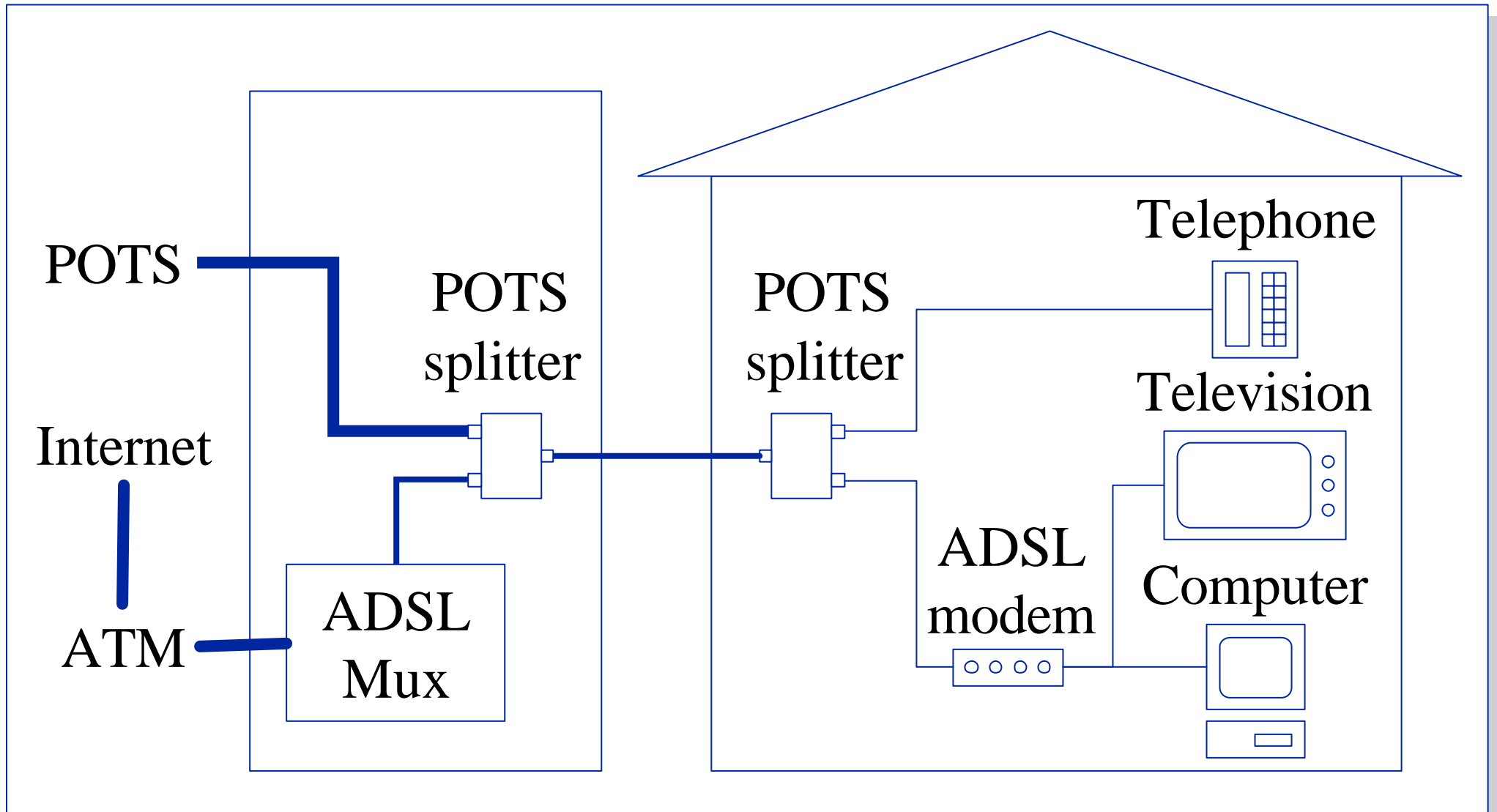

# SOHO ADSL connection

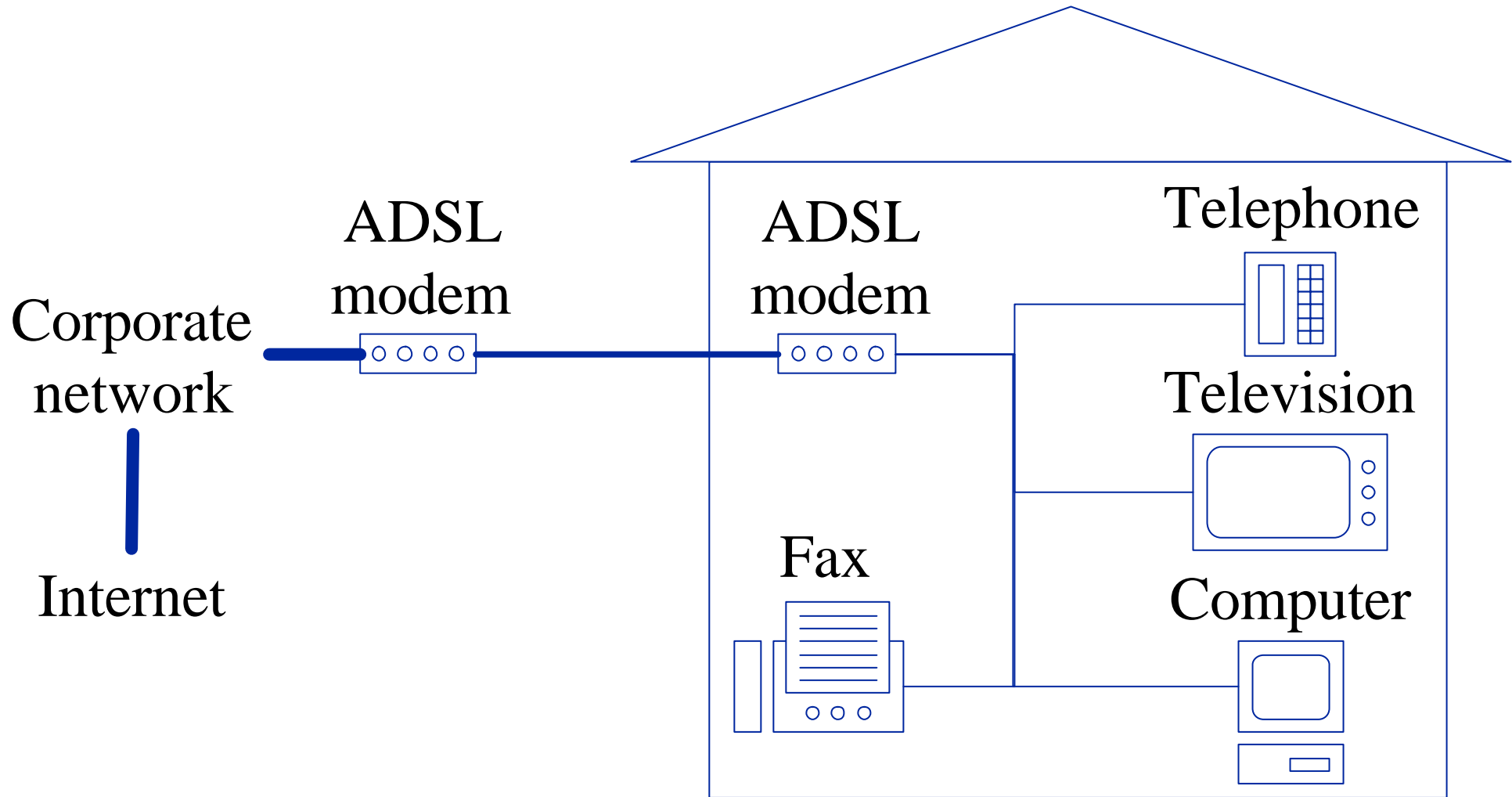

# Different techniques

- IDSL = ISDN
- ADSL = Asymmetric DSL
- R-ADSL = Rate Adaptive ADSL
- HDSL = High Bit-Rate DSL
- SDSL = Symmetric DSL
- VDSL = Very High Bit-Rate DSL

# Distance / Speed

<b>Distance</b>	<b>Speed</b>
5 500 m	1.544 Mbps
4 900 m	2.048 Mbps
3 700 m	6.312 Mbps
2 700 m	8.448 Mbps
1 400 m	12.960 Mbps
900 m	25.820 Mbps
300 m	51.840 Mbps

# ADSL and R-ADSL

- ADSL has asymmetric connection
- 1.5 - 8 Mbps downlink
- 16 - 640 kbps uplink
- R-ADSL adjusts the used frequencies (i.e., rate) automatically

# HDSL and SDSL

- HDSL is already in wide use (business)
- Symmetric connection
- Requires two (1.544 Mbps) or three (2.048 Mbps) twisted pairs
- SDSL uses only one twisted pair (i.e., single line)
- SDSL has shorter distance

# VDSL

- Asymmetric connection
- 13 - 52 Mbps downlink
- 1.5 - 2.3 Mbps uplink
- Speed depends heavily on distance

# xDSL modems

- Two competing technologies
  - + Discrete Multitone (DMT)
  - + Carrierless Amplitude Phase (CAP) Modulation
- Both are based on Quadrature Amplitude Modulation (QAM)
- DMT is much more efficient, but also harder to implement

## xDSL modems (cont.)

- In DMT, the frequency band is divided into 256 sub frequencies (4.3 kHz)
- Each sub frequency has its own transfer rate
- The frequency band can be divided into telephone, downlink, and uplink traffic

# Discrete multitone modulation

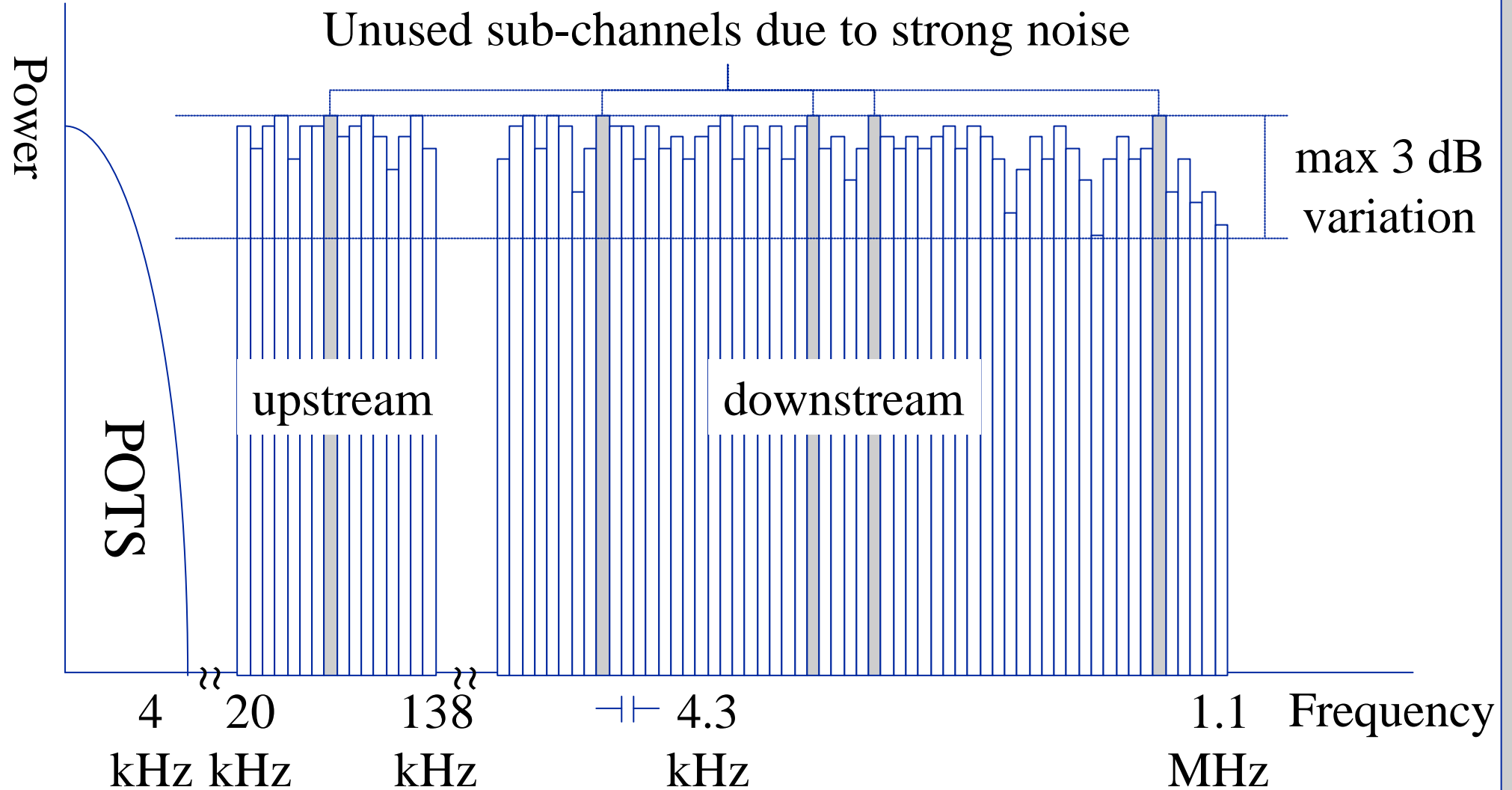

# Elisa Communications ADSL

- Subscription 78 €(offer 8 €)
- Monthly fee

Speed	Fee
256/256k	19.90 €/month
512k/512k	24.90 €/month
1M/512k	36.00 €/month
2M/512k	49.00 €/month
8M/1M	59.00 €/month

# HomePNA

- With HomePNA different apartments can share the same broadband connection
- Based on Ethernet technology
- Physical layer is telephone cable (4-10 MHz)
- HomePNA 1.0: 1 Mbps (150 m)
- HomePNA 2.0: 10 Mbps (350 m)
- Separate adapter or converter required per each apartment

# UMTS

- UMTS is the 3rd generation mobile phone system
- There should be enough bandwidth for multimedia services
- Transfer to UMTS systems is commonly seen as evolution
  - + GSM 2+, WAP, HSCSD, GPRS, EDGE
  - + WCDMA, UMTS

# GSM phase 2+

- **ASCI**: group and broadcast calls
- **GPRS**: packet radio
- **HSCSD**: several data channels (max 64 kbps)
- **CAMEL**: central services
- **EFR**: better voice quality
- multifrequency phones (GSM/DCS1800)
- multistandard phones (GSM/DECT)

# WAP

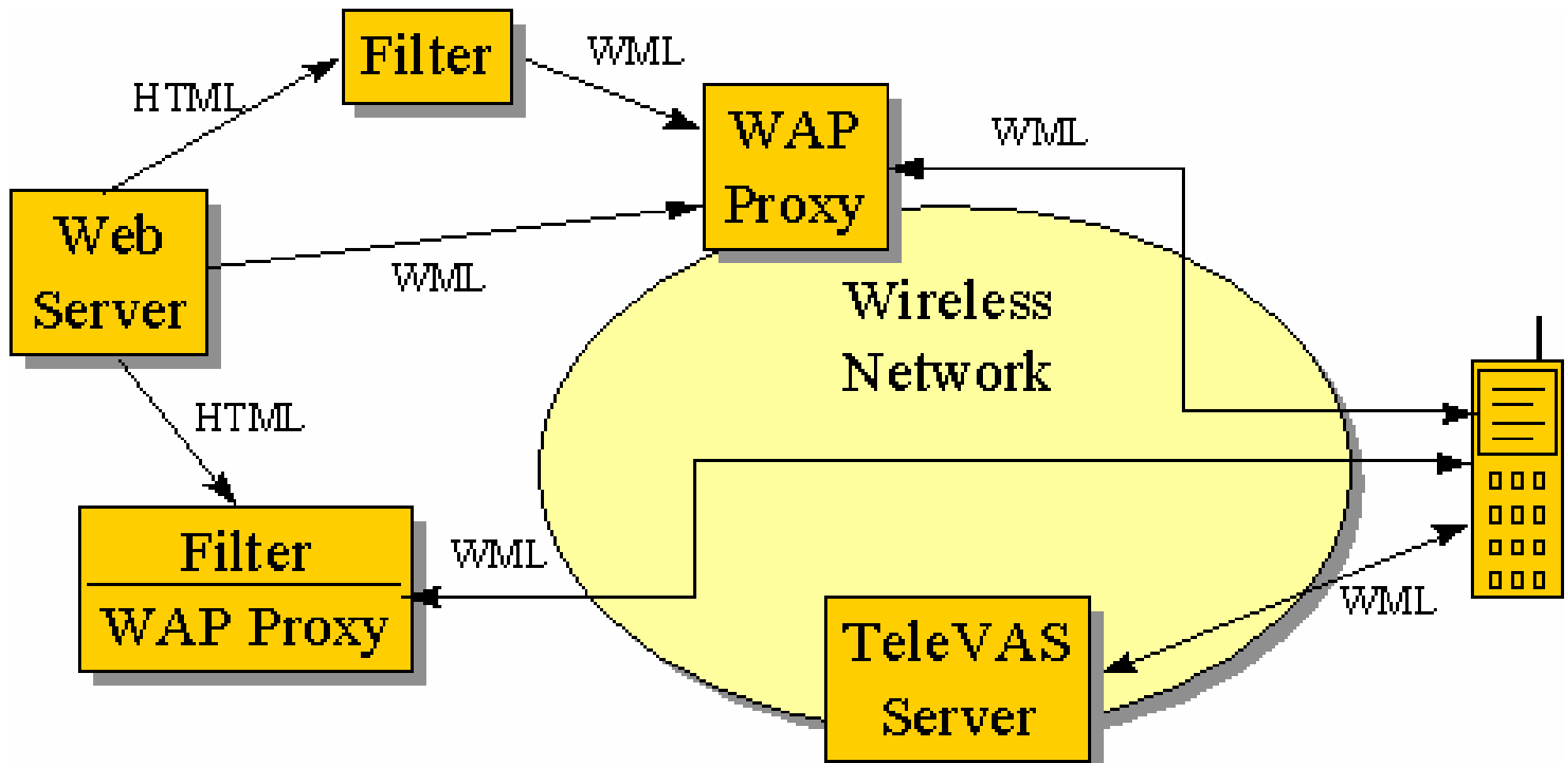

# HSCSD

- High Speed Circuit Switched Data
- Allows the use of more than one GSM data channel at the same time
- In Finland, the service is offered by Sonera
- Requires support from mobile phone
- E.g., Nokia Card Phone 2.0
  - + standard speed 14.4 kbps
  - + triple speed even 43.2 kbps

# GPRS

- General Packet Radio System
- Based on packets - not switched circuits
- Connection is always on and switching is faster
- GPRS uses one GSM radio channel (200 kHz)
  - + Capacity of radio channel is 271 kbps, which is divided into eight 34 kbps data channels
  - + After protocol and error correction speed is 14.4 kbps
  - + GPRS can use all data channel at the same time
  - + capacity is over 100 kbps

# EDGE

- Enhanced Data Rates for Global Evolution
- Packet traffic max 473 kbps
- Circuit switched traffic max 64 kbps

# Bluetooth

- Close range (10-100m) wireless communication
- Radio frequency 2.4 GHz and frequency hopping
- Two data channels
  - + synchronous 64 kbps (max. 3)
  - + asynchronous 721/57.6 kbps (asymmetric) or 432.6 kbps (symmetric)
- Different devices can be connected as piconet
- More than one piconet make scatternet

# Scatternet

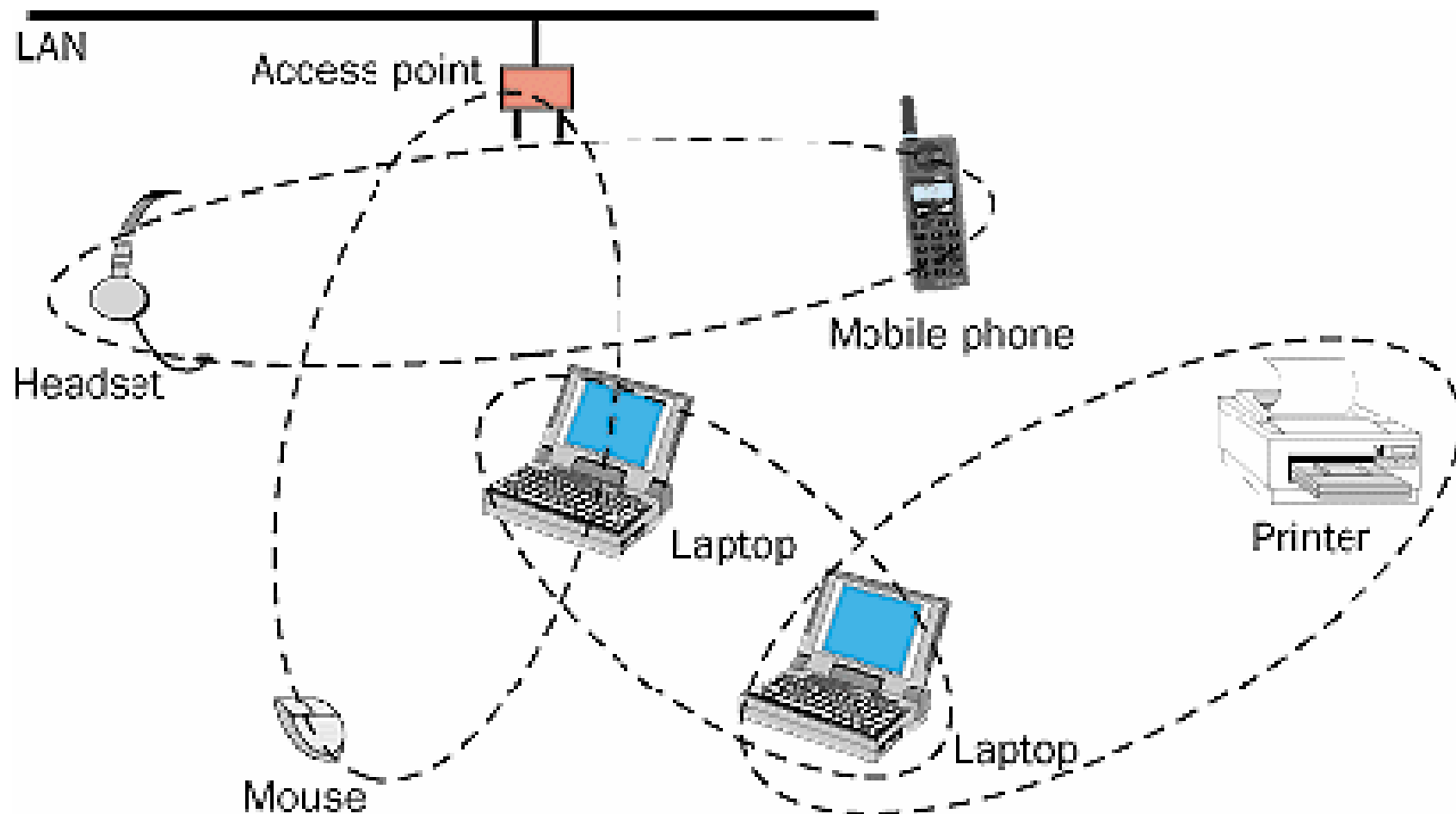

# 3rd generation mobile phones

- ETSI: Universal Mobile Telecommunications System (UMTS)
- ITU: International Mobile Telecommunication 2000 (ITM-2000 / previously FPLMTS)
- ARIB: Association of Radio Industry Business

# UMTS (technology)

- 3rd generation services and system
- Open standard for operators and manufacturers
- Evolution path from current systems (GSM, DCS1800, and DECT)
- Speed up to 2 Mbps
- Restricted use in 2002-3
- Full service 2005

# UMTS (services)

- Mobile: good speech quality and wide range
- PMR: private radiophone systems
- Peeper: small receiver and global use
- Wireless phone: excellent capacity in limited area
- Satellite: Global use everywhere
- Airplane: possible

# UMTS (cells)

The principle behind hierarchical cell structure

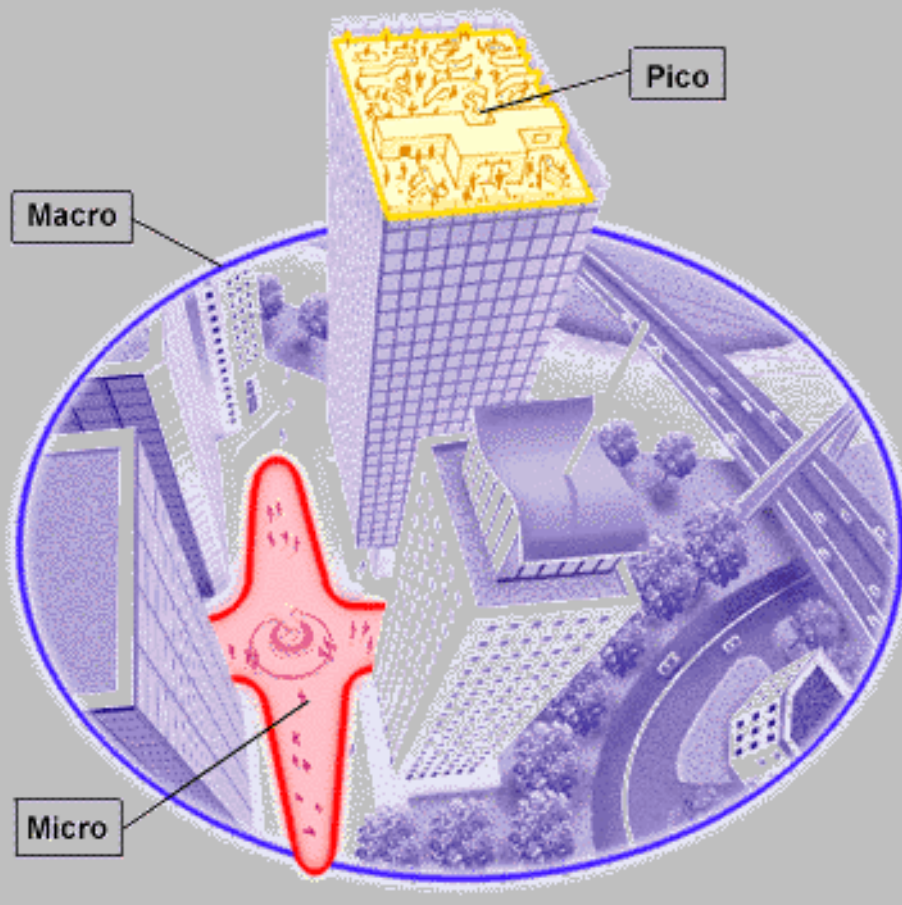

- satellite: country
- macro:  $< 30$  km
- mini:  $< 3$  km
- micro: few streets
- pico: office room, train, airplane, etc.

# UMTS (development)

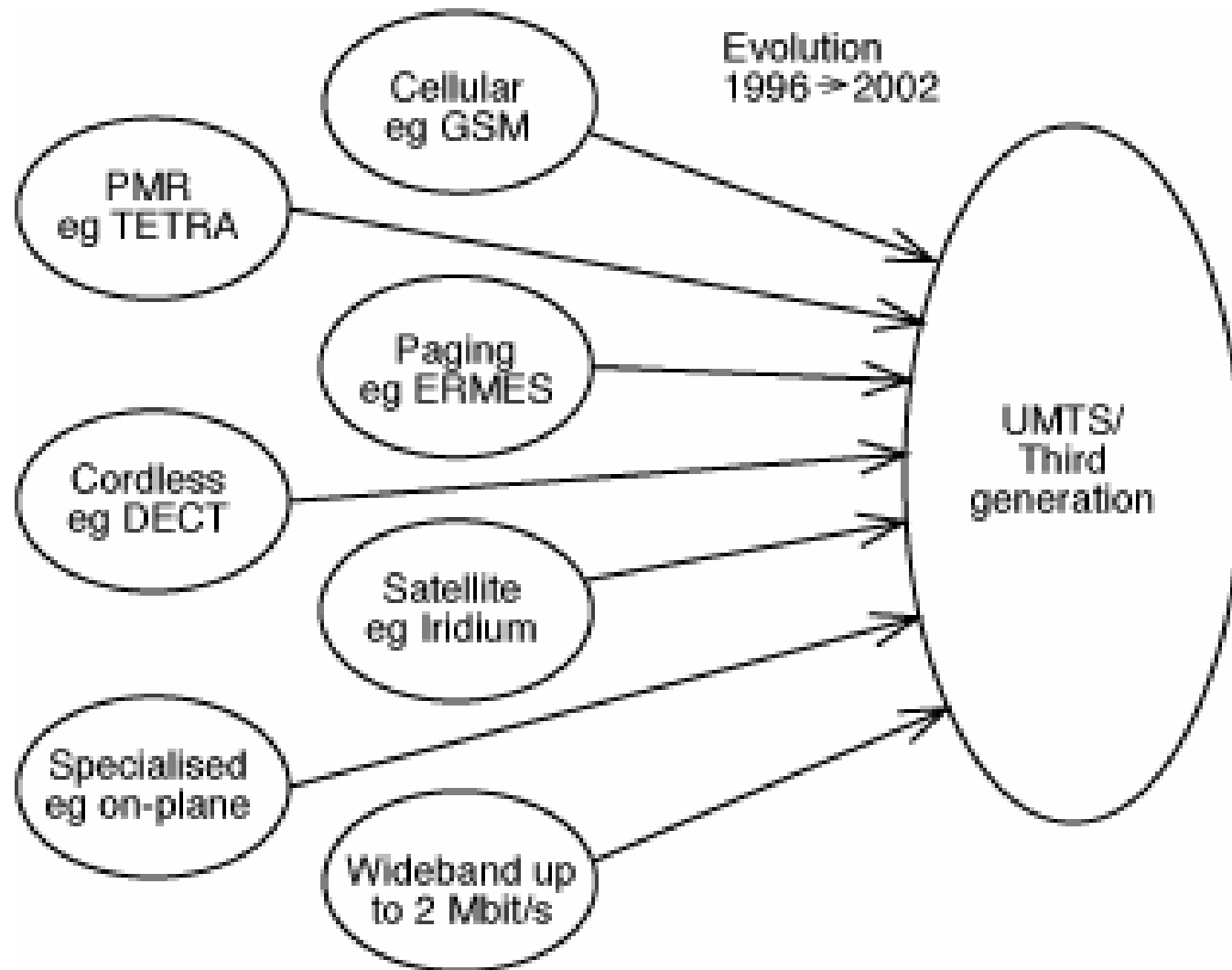

# UMTS (evolution)

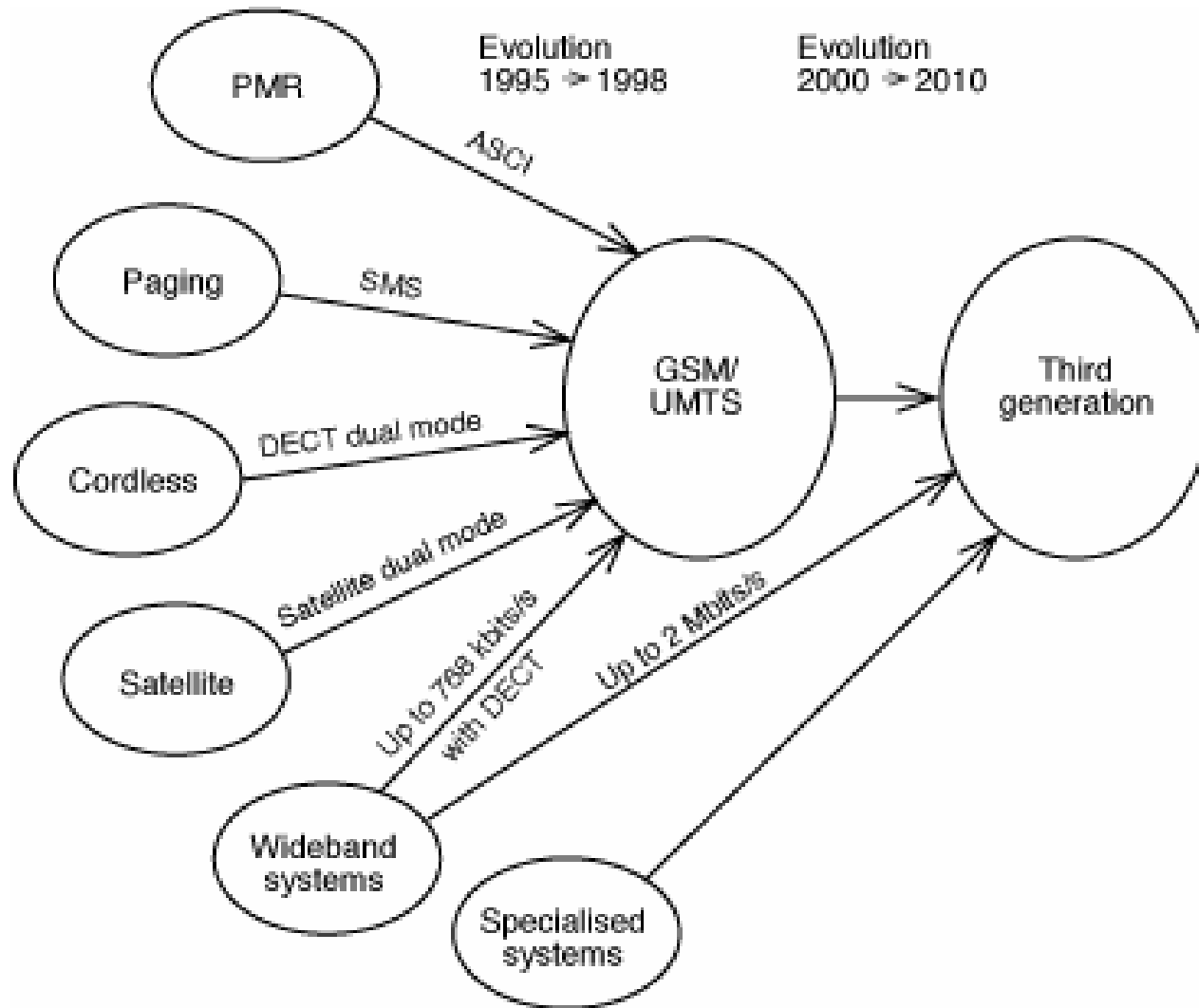

# Competing proposals

- USA:
  - + CDMA and IS-41 (AMPS)
- Nokia, Ericsson, and NTT-DoCoMo:
  - + WCDMA and GSM
- Alcatel and Siemens:
  - + TCDMA and GSM

# WCDMA

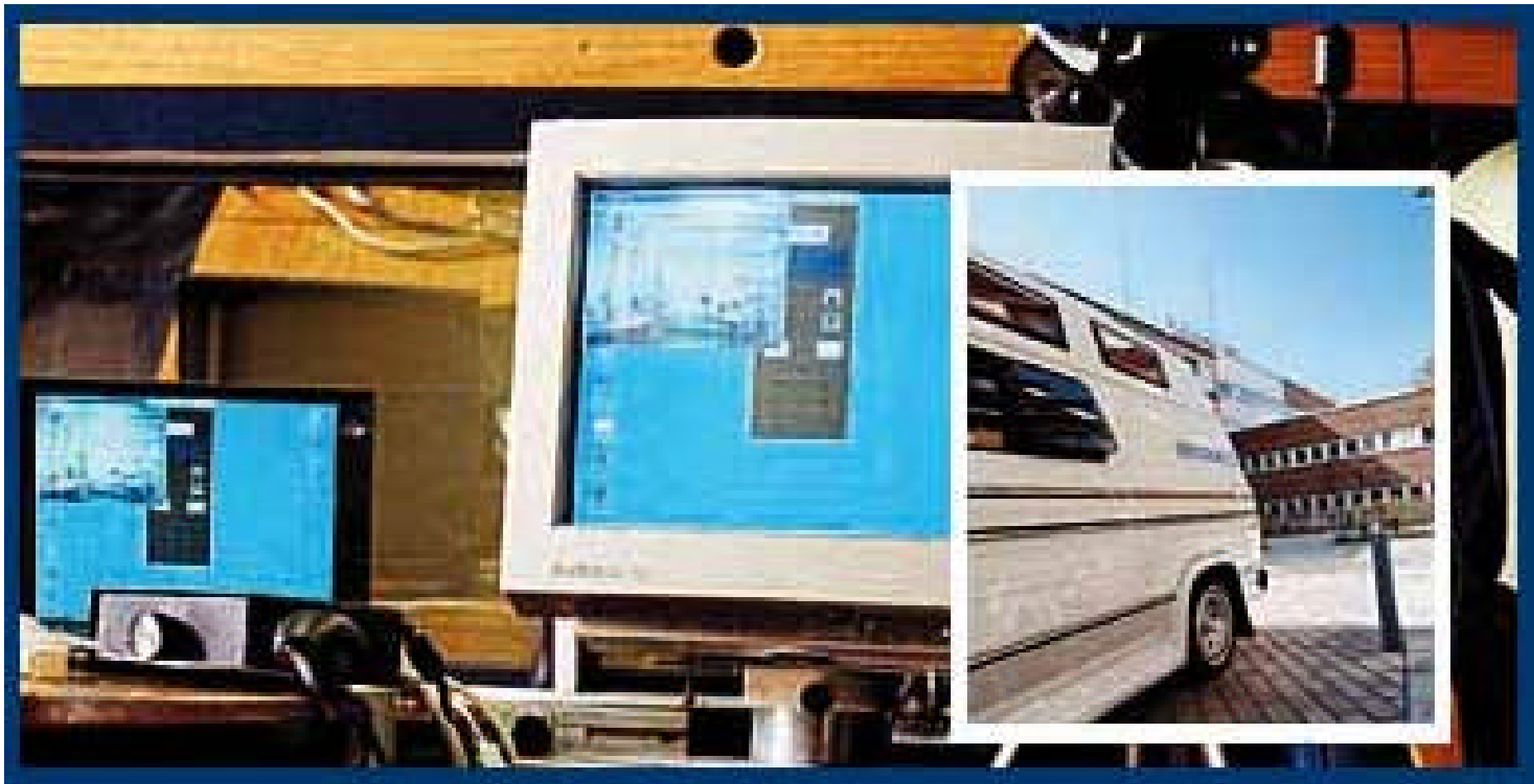

Ericsson's WCDMA Test Bed in Sweden

# WCDMA (technology)

- Frequency 2 GHz and band 5 Mhz
- 8 - 384 kbps outside and max 2 Mbps indoors
- 50 packet data users or 100 calls
- Transport ATM Adaptation layer 2 (AAL.2)
- Adaptive Antenna Arrays
- Hierarchical cells

# Digital television

## Digital broadcasts:

- more channels
- better quality

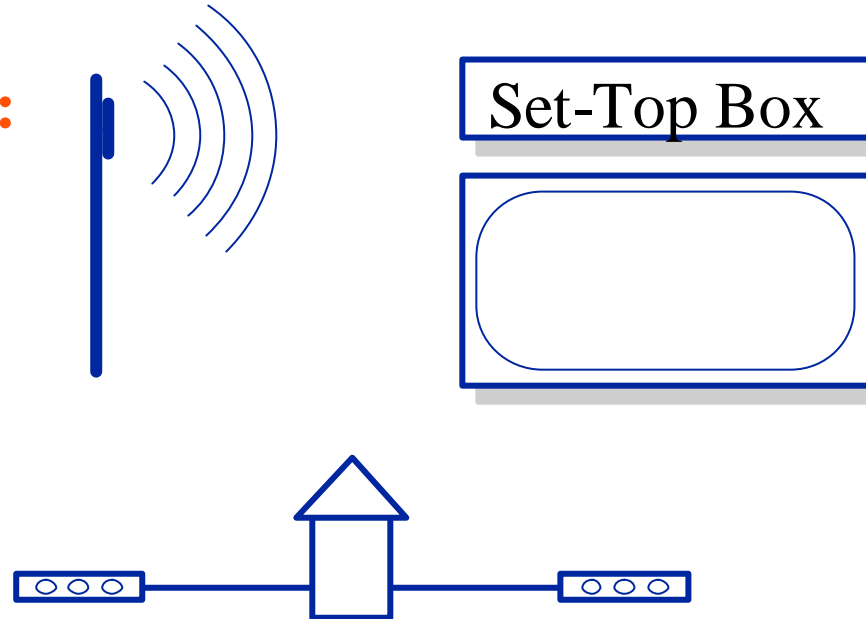

## Set-top box:

- cheap computer
- multimedia

## Return channel:

- Interactive services
- Internet

# Technology

## Broadcast:

- terrestrial
- cable
- satellite

## Databases:

- content
- services
- users
- billing

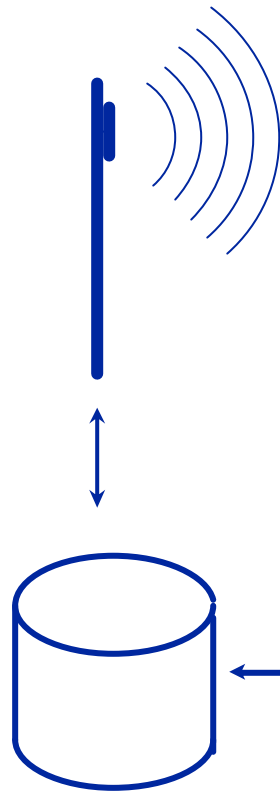

## Network

- Internet
- ATM

Set-Top Box



## Return channel

- analog modem
- xDSL
- cable modem

# Transmission technology

- Digital television uses MPEG2 encoded video signal
- Transmissions use several technologies
  - + modulation
  - + error protection
  - + multi carrier
  - + one or multi frequency network
- Depending on chosen parameters the capacity is 4.98 - 31.67 Mbps

# Modulation

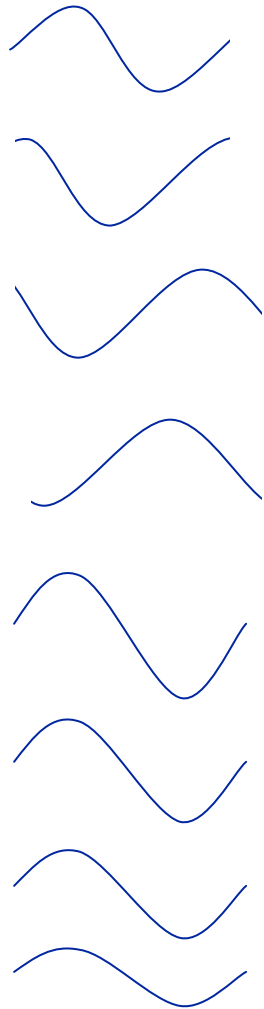

- Based on advanced modulation
  - + QPSK
  - + 16-QAM
  - + 64-QAM
- By changing both signal phase and amplitude 4, 16, or 64 bits can be sent at once

# Multi carrier

- Multi carrier transmissions use several adjacent frequencies at the same time
  - + 2 K
  - + 8 K
- Transmission is composed of bursts (i.e., symbols) and protection zones
- Because of this reflection do not cause problems

# Transmission capacity

- In practice the capacity of one transmitter (i.e., mux) is over 20 Mbps
- One “television channel” requires 4-5 Mbps and “high definition TV” 10-15 Mbps
- In Finland, 3 transmission networks (i.e., 12 “digital” channels) will be build
- Same frequency can be used (SFN/MFN)
- Satellite and cable transmissions use wider frequency band and have more capacity

# Receivers

- At least in the beginning, the receivers will be separate set-top boxes
- The terminal demodulates the digital transmission and encoded video, audio, and data
- For encrypted transmissions there is a separate smart card
- Return channel requires a modem (analog, xDSL, or cable)

# Conclusions

	Cable	ADSL	UMTS	DigiTV
Prize	++	--	---	+++
Capacity	+	++	+	+++
Return capacity	+	+	+	--
Mobility	---	---	+++	---

# Future

## Digital television

